



1st Chemical Process Safety Sharing (CPSS)

13 Jun. 2018, Thailand

Emergency Isolation Valves (EIVs)

Presenter Name: Thanasan Tangchaksuwan
Process Technology
PTTGC

CSB: CASE STUDY

Fire at Formosa Plastics Corporation (October 6, 2005)



Emergency Isolation Valves (EIVs)

CSB: CASE STUDY

Fire at Formosa Plastics Corporation
October 6, 2005

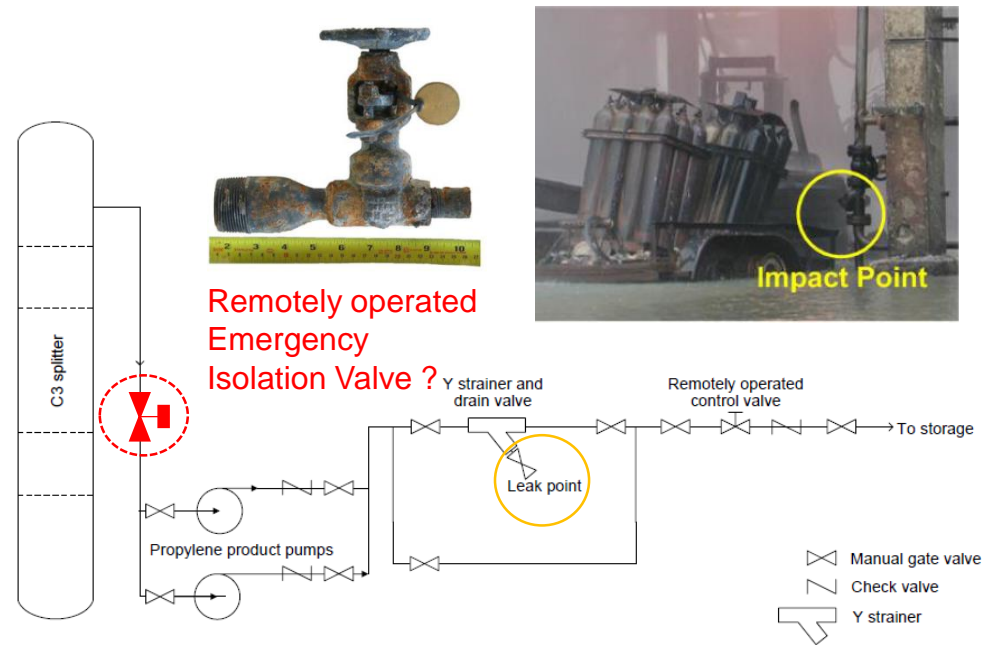

Consequences

- Fire burned for 5 days, 7M gal of water was used for cooldown during fire fighting
- Extensive damage, Shutdown Olefin II 5 months
- 16 worker injuries(1 seriously)
- Damage Cost 50 M\$U.S.

Lessons Learned

- Fireproofing of equipment and automated valves to shut off chemical releases could have greatly reduced the explosion's impact

How to mitigate risk ?

Incident Analysis

1. Vehicle Impact Protection

- ASME B31.3 "Impact forces caused by external..."

2. Structural Steel Fire Protection

- API 2218 Fireproofing Practice

3. Remote Equipment Isolation

- Design guidance Kletz(1998) and HSE (1999)

4. Flame Resistant Clothing

- OSHA PPE Standard, 29 CFR 1910.132., NFPA (2001)

What is Emergency Isolation Valves ?

HSE: Remotely operated shutoff valves(ROSOVs)

“A valve designed, installed and maintained for the primary purpose of achieving rapid isolation of plant items containing hazardous substances in the event of a failure of the primary containment system (including, but not limited to, leaks from pipework, flanges, and pump seals). Closure of the valve can be initiated from a point remote from the valve itself. The valve should be capable of closing and maintaining tight shutoff under foreseeable conditions following such a failure (which may include fire).”

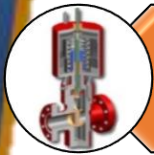

Fail Safe



Fire Safe



Operate Safe

- Emergency Isolation Valves (EIVs)
- Remotely operated shutoff valves (ROSOVs)
- Emergency Shutdown valves(ESDVs)
- Emergency Block Valves (EBVs)

When to consider fitting a EIVs ?

HSE: Remotely operated shutoff valves(ROSOVs)

“ You should assesses the need to fit a EIVs wherever there is the *potential for a major accident as a result of loss of containment of a hazardous substance*, the consequence of which could be significantly reduced by rapid isolation”



- Key consideration factors
 - The nature and properties of the substance
 - The quantity of substance released
 - The size and nature of populations at risk
- Type and location of valve based on the result of a process hazards evaluation.
- Fireproof cable, valve and auxiliary parts should be considered.

Substance Properties

Liquefied Petroleum Gas (Refer to NFPA 58)

Any material having a vapor pressure not exceeding that allowed for commercial propane that is composed predominantly of the following hydrocarbons, either by themselves (except propylene) or as mixtures: propane, propylene, butane (normal butane or isobutane), and butylenes.

Flammable Liquid (Refer to NFPA 30)

NFPA 30 Category	Flash Point (°C)	Initial Boiling Point (°C)
IA	< 22.8	< 37.8
IB	< 22.8	≥ 37.8
IC	≥ 22.8	Note: Flammable
II	≥ 37.8 and < 60	Liquids are Class I and
IIIA	≥ 60 and < 93	Combustible liquids
IIIB	≥ 93	are Class II & III

Flammable Liquid

Combustion Liquid

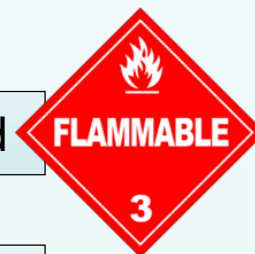

Toxic Material : hazardous and toxicity - > SDS

Guidelines: Compressor

(Refer to API RP 553)

- EIVs are typically required for all compressors **200 HP or larger handling flammable or toxic materials.**
- An EIV is needed in all suction and discharge lines.
- Inter-stage equipment if the inter-stage equipment holds greater than **3.8 m³ (1000 gallons)** of liquid.

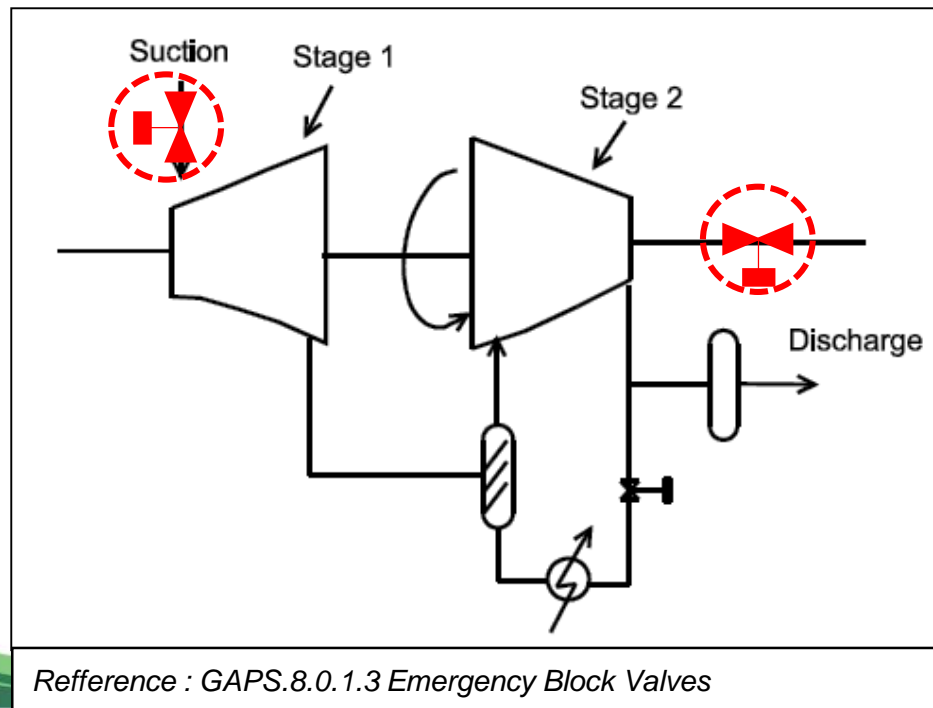

Guidelines: Storage Tank, Column, Vessel and Pump

Material		API RP 553	NFPA 58
LPG	Require		1000 gal 3.8 m ³
Hydrocarbon above Auto Ignition Temp	Recommend	7.6 m ³	
Hydrocarbon (Flammable Liquid)	Recommend	15 m ³	

NFPA 58 : Liquefied Petroleum Gas Code

- 1000 – 4000 gal complied within 2024
- Greater 4000 gal complied within 2011

- Situate the valve as close as possible to the bottom to reduce the length of exposed piping and liquid.
- Pumps with high pressure discharge shall have a EIV at its discharge
- Review each system carefully to ensure the correct types of valves

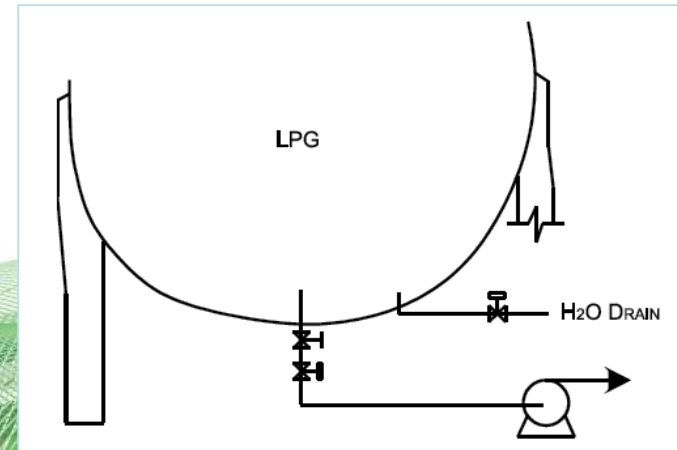
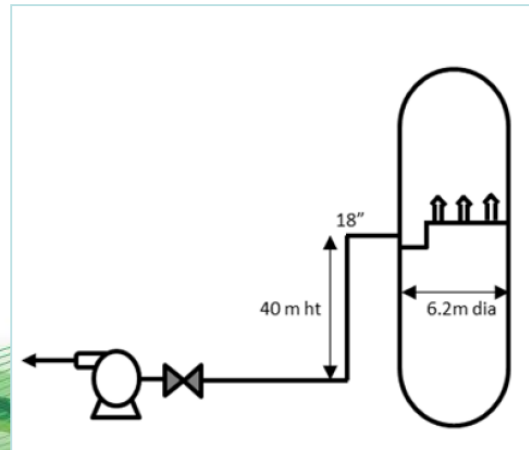
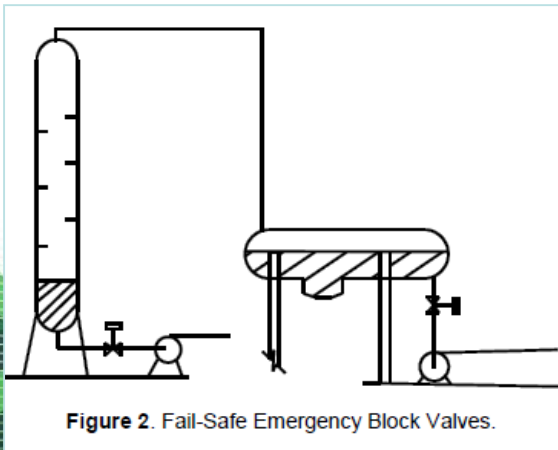

Reference : GAPS.8.0.1.3 Emergency Block Valves

Emergency Isolation Valves at Pump Suction: Application for Flammable Liquids

Guidelines: Liquefied Petroleum Gas Code

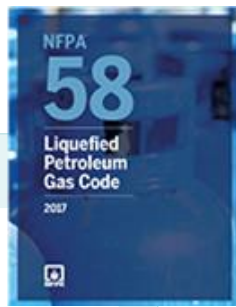

LPG: 1000 - 4000 gal

1

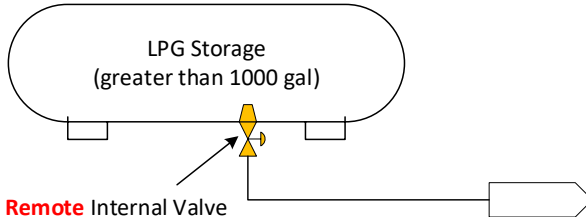

2

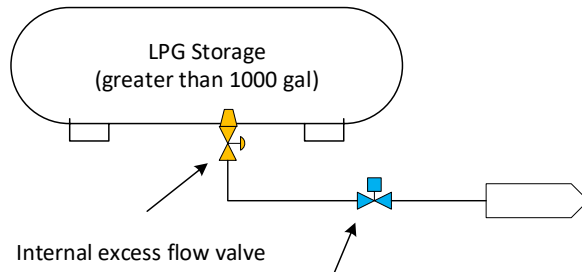

3

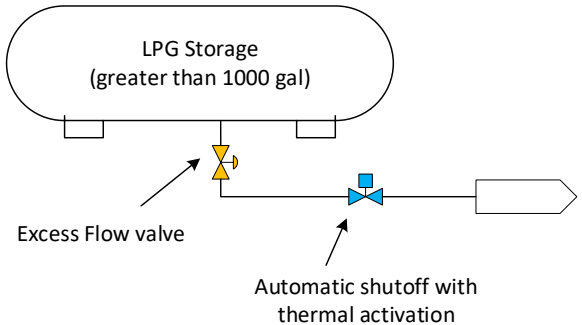

Complied within 2024

LPG: > 4000 gal

1

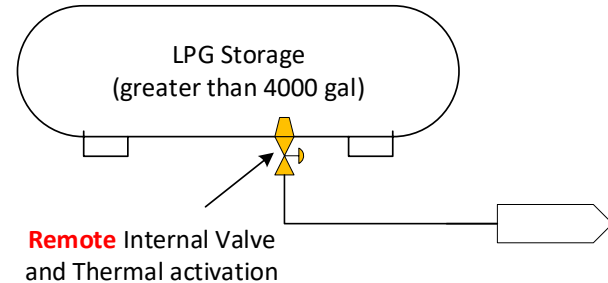

2

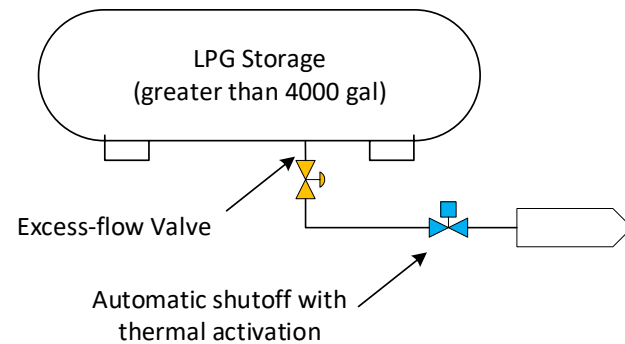

Complied within 2011

Guidelines: Fired Heaters

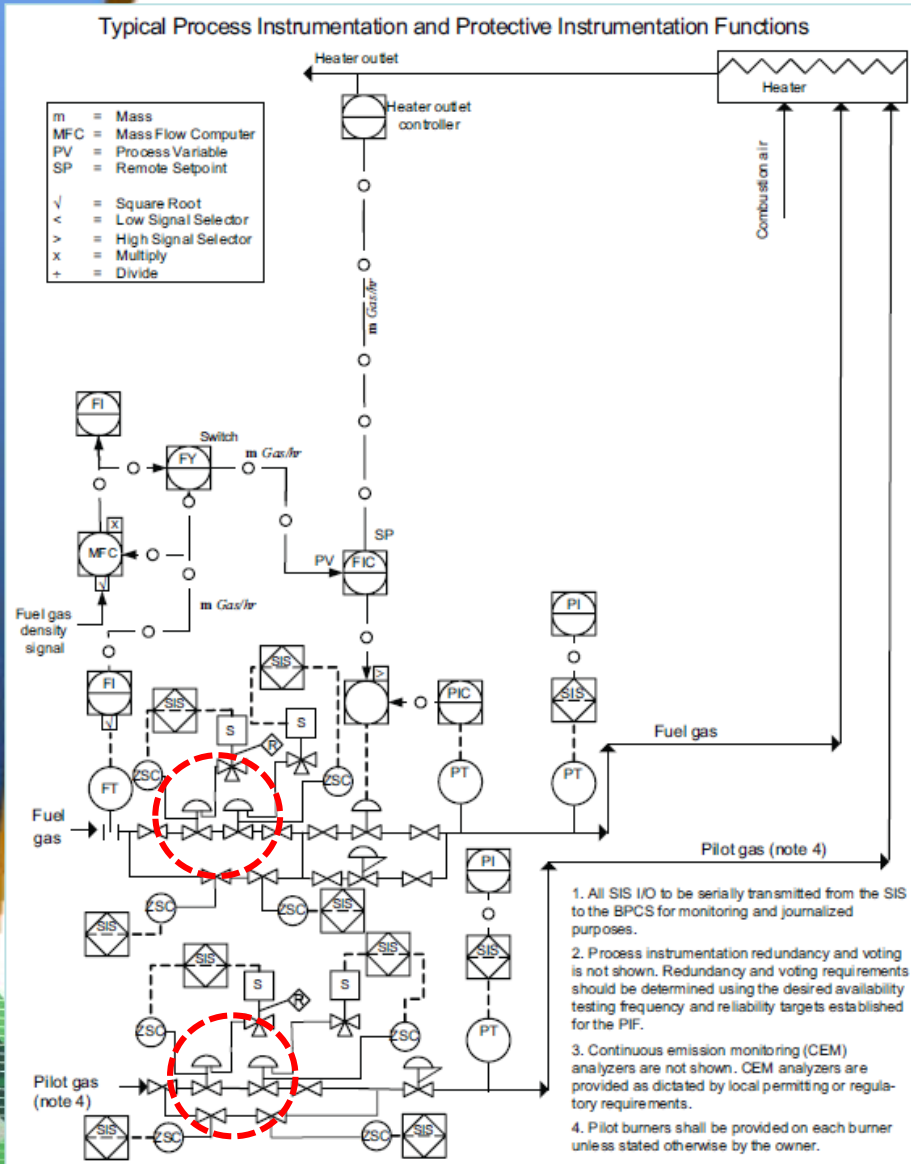

API RP 556: Instrumentation, Control, and Protective Systems for Gas Fired Heaters.

- Safety Shutoff valves are used to isolate fuel sources to a heater after initiation by any of the protective functions.
- Fail-safe (spring return fail closed), not have hand wheels
- Tight shutoff ANSI/FCI 70-2 Class V or VI
- Maximum Travel time
 - Up to 4 in < 3 seconds
 - 6 – 8 in < 4 seconds
 - 8 – 12 in < 5 seconds
- Two valve in series be used to isolate fuel gas, one-out-of-two (1oo2) Voting, allow for higher performance (SIL) rating.

Reference :API RP 556: Instrumentation, Control, and Protective Systems for Gas Fired Heaters

Guidelines: Loading

Marine Terminals

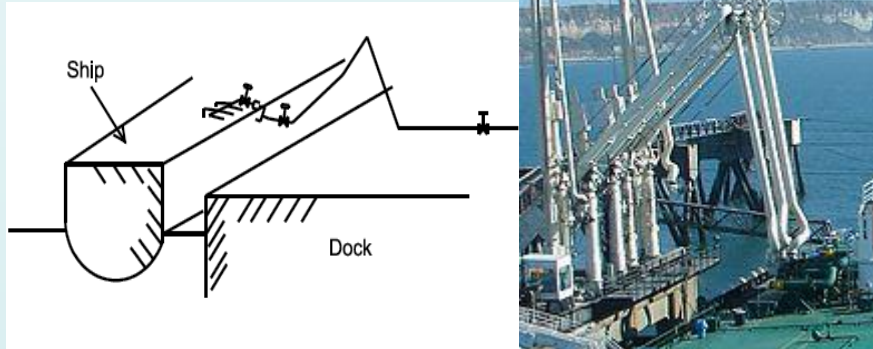

- Install on each side of the connecting flange of all loading arms
- Install push button controls in control room and local area
- Close oil loading in a minimum 30 S.
- Close gas line as fast as possible

Loading Terminals

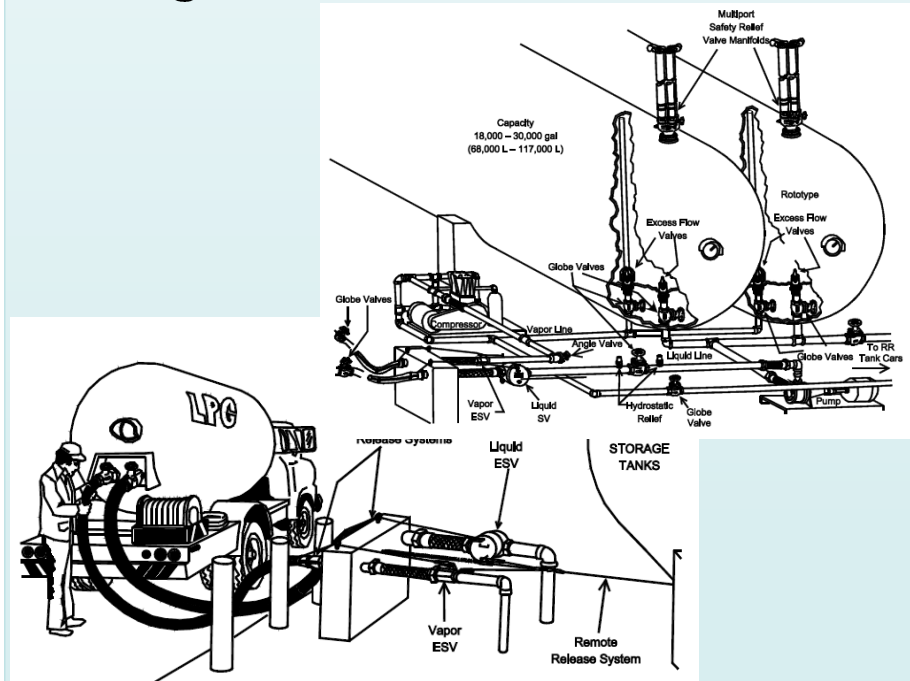

- Fit both the truck fill and the vapor recovery line with EIVs(Fail- safe)
- Install excess flow valves in the loading arm pipe work to avoid large spills.
- Install interlock between grounding wire and the shipping pumps to prevent static electricity buildup. (NFPA 77)

Reference : GAPS.8.0.1.3 Emergency Block Valves

Conclusion



Loss of containment(LoC) from equipment and piping can protect and mitigate by Emergency Isolation Valves (EIVs)



The requirement of EIVs should considered base on properties, quantity, likelihood and consequence in risk assessment.



For LPGs services, consider requirements in NFPA 58



For Fired Heaters, EIVs shall be considered based on API RP 556 and NFPA 85.



Routine maintenance shall be provided for EIVs to maintain reliability of Loss of Containment Protection of Plants.



Chemical Process Safety Sharing (CPSS)



Thank you for your attention



1st Chemical Process Safety Sharing (CPSS)
13 Jun. 2018, Thailand



Guidelines: Liquefied Petroleum Gas Code

5.9.4 Container Valves and Other Appurtenances.

5.9.4.1 Containers of 4000 gal (15.2 m³) water capacity or less shall comply with 5.9.4.1(A) through 5.9.4.1(D).

(D) Containers utilized in stationary service having water capacities greater than 1000 gal (3.8 m³) and not exceeding 4000 gal (15.2 m³) water capacity and utilizing a liquid withdrawal opening for liquid service shall be equipped with one of the following:

- 1 (1) An internal valve fitted for remote closure and automatic shutoff equipped with thermal activation
- 2 (2) An emergency shutoff valve fitted for remote closure and automatic shutoff equipped with thermal activation, installed in a line downstream close to a positive shutoff valve in combination with an excess-flow valve installed in the container
- 3 (3) Container openings that are not compatible with internal valves shall be permitted to utilize both an excess-flow valve installed at the container and a valve complying with

API 607, *Fire Test for Quarter-Turn Valves and Valves Equipped with Non-Metallic Seats*, with the following features:

- (a) The valve shall be activated either hydraulically or pneumatically and shall fail in the closed position.
 - (b) The valve shall be equipped for remote closure and equipped with thermal actuation.
- (4) Remote actuation devices required in (1), (2), and (3) shall be located not less than 10 ft (3.1 m) or more than 100 ft (30.5 m) along a path of egress from the liquid transfer point into the container.
 - (5) For existing installations, the requirements in (D) shall be complied with by January 1, 2024.

LPG: 1000 - 4000 gal

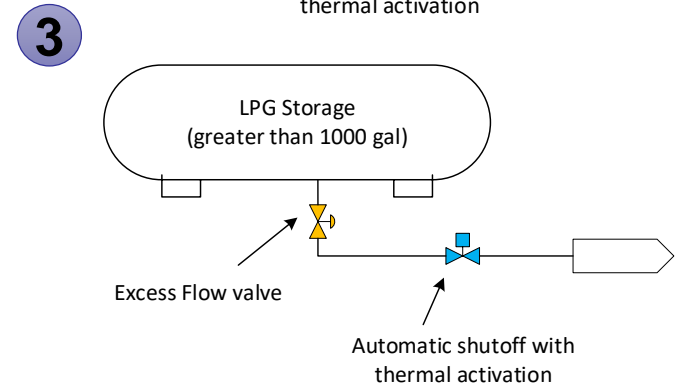
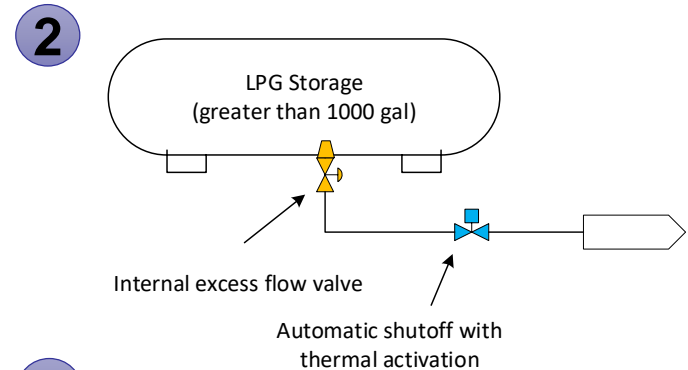
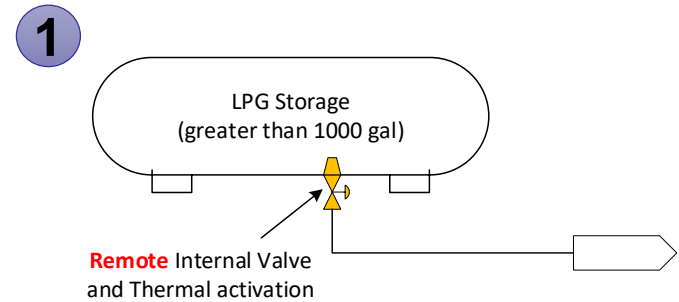

Complied within 2024

Guidelines: Liquefied Petroleum Gas Code



5.9.4.2 ASME containers greater than 4000 gal (15.2 m³) water capacity shall be fitted with valves and other appurtenances in accordance with 5.9.4.2(A) through 5.9.4.2(I) and Table 5.9.4.2.

(A) Vapor withdrawal openings shall be equipped with either of the following:

(1) A positive shutoff valve located as close to the container as practical in combination with an excess-flow valve installed in the container

1 An internal valve

(B) Liquid withdrawal openings in new installations shall be equipped with an internal valve that is fitted for remote closure and automatic shutoff using thermal (fire) actuation where the thermal element is located within 5 ft (1.5 m) of the internal valve.

(C) Liquid withdrawal openings in existing installations where the container is equipped with an internal valve that is not fitted for remote closure and automatic shutoff using thermal (fire) actuation shall be equipped for remote and thermal closure by July 1, 2003.

(D) Liquid withdrawal openings in existing installations shall be equipped with either of the following by July 1, 2011:

(1) An internal valve that is fitted for remote closure and automatic shutoff using thermal (fire) actuation where the thermal element is located within 5 ft (1.5 m) of the internal valve

2 An emergency shutoff valve that is installed in the line downstream as close as practical to a positive shutoff valve in combination with an excess-flow valve installed in the container

LPG: > 4000 gal

1

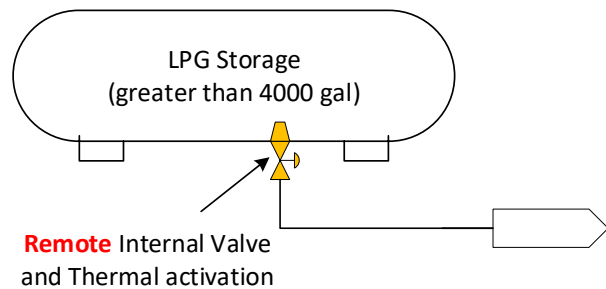

2

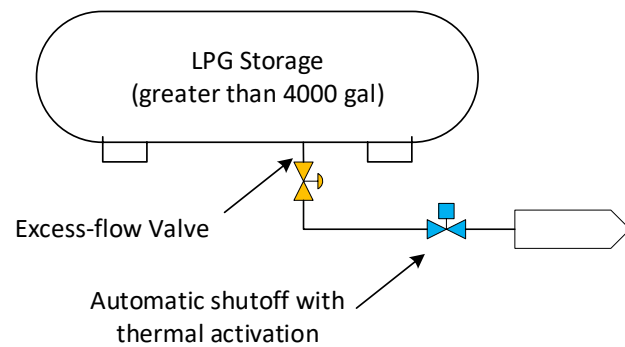

Complied within 2011

The process of assessment in the context of ROSOVs

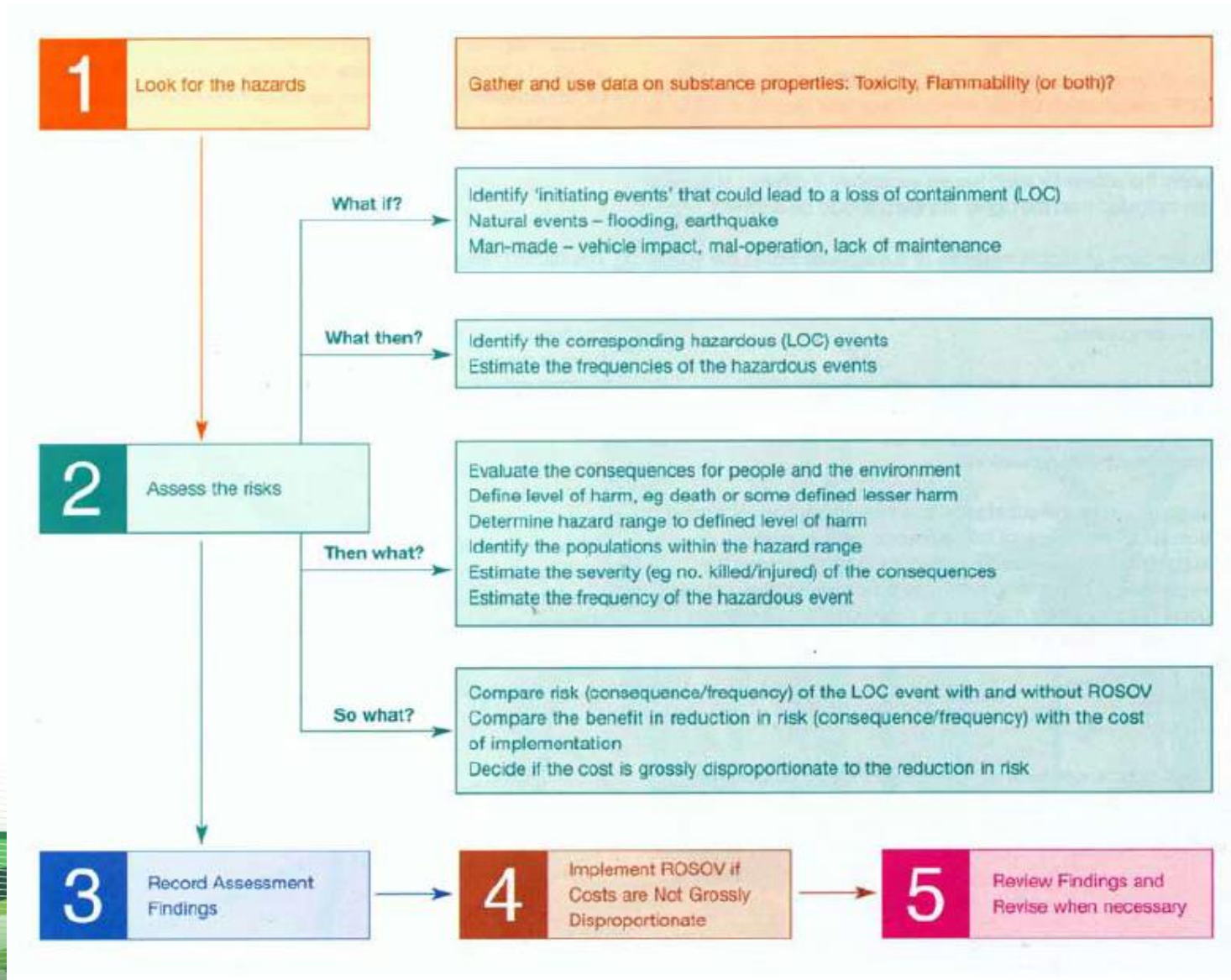

ข้อบังคับคณะกรรมการการนิคมอุตสาหกรรมแห่งประเทศไทย

ว่าด้วยหลักเกณฑ์ วิธีการ และเงื่อนไขในการประกอบกิจการในนิคมอุตสาหกรรม

(ฉบับที่ ๔)

พ.ศ. ๒๕๕๙

ข้อ ๒๙/๑๐ ผู้ประกอบอุตสาหกรรมต้องจัดทำเอกสารเพื่อแสดงว่าอุปกรณ์เป็นไปตามมาตรฐาน และวิธีปฏิบัติทางวิศวกรรมที่ดีที่ได้รับการรับรองและเป็นที่ยอมรับโดยทั่วไป (Recognized and Generally Accepted Good Engineering Practices: RAGAGEP) สำหรับอุปกรณ์ที่ออกแบบและก่อสร้าง ตามข้อกำหนดมาตรฐานเดิมที่ไม่ได้ใช้งานแล้ว ผู้ประกอบอุตสาหกรรมจะต้องจัดทำเอกสารเพื่อแสดงว่า อุปกรณ์นั้นได้ถูกออกแบบ บำรุงรักษา ตรวจสอบ ทดสอบ และสามารถใช้งานได้อย่างปลอดภัย

Reference

- API RP 553 : Refinery Valves and Accessories for Control and Safety Instrumented Systems
- API 2510 : Design and Construction of LPG Installations
- NFPA 30 : Flammable and Combustible Liquid Code
- NFPA 58 : Liquefied Petroleum Gas Code
- DEP: 01.00.02.13 PROCESS ENGINEERING AND SAFEGUARDING PRACTICES (PRENSAP)
- API RP 556: Instrumentation, Control, and Protective Systems for Gas Fired Heaters
- HSE Remotely operated shutoff valves (ROSOVs) HSG244
- *GAPS.8.0.1.3 Emergency Block Valves*
- CSB CASE STUDY: Fire at Formosa plastics corporation 2005
- NFPA 77 : Recommended Practice on Static Electricity

-